

# DESIGN NOTES

## The LT1370: A 500kHz, 6A Monolithic Boost Converter

Design Note 183

Karl Edwards

Complementing and expanding on the current LT<sup>®</sup>1371/LT1372 family of 500kHz switchers, Linear Technology introduces the LT1370, a 6A boost converter. A high efficiency switch is included on the die, along with all the oscillator, control and protection circuitry necessary for a complete switching regulator. This part combines the convenience and low parts count of a monolithic solution with the switching capabilities of a discrete power device and controller. At 0.065Ω on-resistance, 42V maximum switch voltage and 500kHz switching frequency, the LT1370 can be used in a wide range of output voltage and current applications. Only a few surface mount components are needed to complete a small, high efficiency DC/DC converter. LT1370 features include current mode operation, external synchronization and low current shutdown mode (12μA typical).

### Circuit Description

The LT1370 is a current mode switcher. This means that switch duty cycle is directly controlled by the switch current rather than by the output voltage. This technique has several advantages: immediate response to input voltage variations, greatly simplified closed-loop frequency compensation, and pulse-by-pulse current limiting, which provides maximum switch protection. An internal low dropout regulator provides a 2.3V supply to all control circuitry. This low dropout design allows the input voltage to vary from 2.7V to 30V with virtually no change in device performance. An internal 500kHz oscillator is the basic clock for all timing. A bandgap provides the reference for the feedback error amplifier.

As with the LT1371, error amplifier circuitry allows the LT1370 to directly regulate negative output voltages. The NFB pin regulates at -2.48V, while the amplifier's output internally drives the FB pin to 1.245V. The error amplifier is a current output ( $g_m$ ) type, so its output voltage, present on the  $V_C$  pin, can be externally clamped to lower the current limit. A capacitor-coupled external clamp provides soft start.

The S/S pin has two functions: synchronization and shutdown. The internal oscillator can be synchronized to a

higher frequency by applying a TTL square wave to this pin. This allows the part to be synchronized to a system clock. If the S/S pin is held low, the LT1370 will enter shutdown mode. In this mode, all internal circuitry is disabled, reducing supply current to 12μA. An internal pull-up ensures start-up when the S/S pin is left open circuit.

### 5V to 12V Boost Converter

Figure 1 shows a typical 5V to 12V boost application. The high 6A switch rating permits the circuit to deliver up to

LT, LTC and LT are registered trademarks of Linear Technology Corporation.

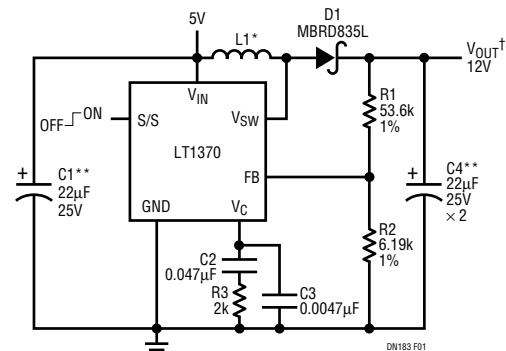

\*COILTRONICS  
(561) 241-7876  
UP2-4R7 (4.7μH)  
UP4-100 (10μH)  
\*\*AVX TPSD226M025R0200

†MAX I <sub>OUT</sub>	
L1	I <sub>OUT</sub>
4.7μH	1.8A
10μH	2.0A

Figure 1. 5V to 12V Boost Converter

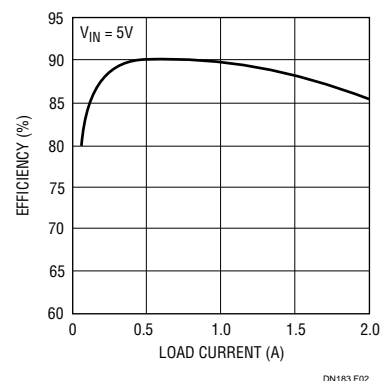

Figure 2. 12V Output Efficiency

24W. Figure 2 shows the overall converter efficiency. Notice that peak efficiency is 90%; efficiency stays above 86% at the circuit's maximum 2A output current. The inductor needs to be chosen carefully to meet peak current values. The output capacitor can see high ripple currents—often, as in this application, higher than the ripple rating of a single capacitor. This requires the use of two surface mount tantalums in parallel; both capacitors should be of the same value and manufacturer. The input capacitor does not have to endure such high ripple currents and a single capacitor will normally suffice. The catch diode, D1, must be rated for the output voltage and average output current. The compensation capacitor, C2, normally forms a pole in the 2Hz to 20Hz range, with a series resistor, R3, to add a zero at 1kHz to 5kHz. The S/S pin in this example is driven by a logical on/off signal, a low input forcing the LT1370 into its 12 $\mu$ A shutdown mode.

### Positive to Negative Converter

The negative feedback (NFB) pin, enables negative output regulators to be designed with direct feedback. In the circuit shown in Figure 3, a 2.7V to 13V input, -5V output converter, the output is monitored by the NFB pin and a simple divider network. No complex level shifting or unusual grounding techniques are required. The S/S pin is used to synchronize the switching frequency to a 600kHz external clock signal.

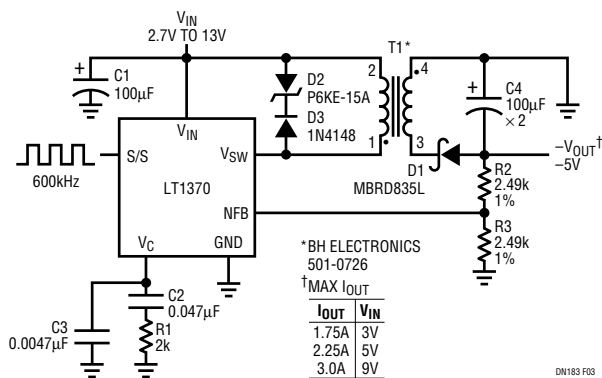

Figure 3. Positive to Negative Converter with Direct Feedback

The switch clamp diodes, D2 and D3, prevent the leakage spike from the transformer, T1, from exceeding the switch's absolute maximum voltage rating. The Zener voltage of D2 must be higher than the output voltage, but low enough that the sum of input voltage and clamp voltage does not exceed the switch-voltage rating.

### 5V SEPIC Converter

Figure 4 is an example of a SEPIC converter. The SEPIC topology has the advantage of an input voltage range that extends both above and below the output voltage. In Figure 4, the batteries can be at a charge level from 9V to below 4V while maintaining a fixed 5V output. Also, there is no direct path from input to output. When the S/S pin is grounded, forcing the LT1370 into shutdown, there is no leakage into the output. In shutdown, battery current is reduced to 12 $\mu$ A, the input current of the LT1370. The magnetic coupling of inductors L1A and L1B is not critical for operation, but generally they are wound on the same core. C2 couples the inductors together and eliminates the need for a switch snubber network.

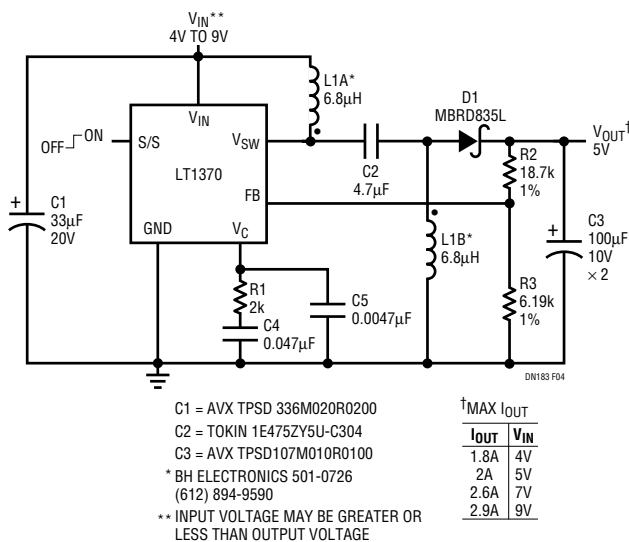

Figure 4. Two Li-Ion Cells to 5V SEPIC Converter

### Conclusion

With its low resistance switch, 6A operating current and 500kHz operation, the LT1370 is ideal for small, low parts count, high current applications. Its high switching frequency removes the need for large bulky magnetics and capacitors. Compared to a separate control device and power switch, the LT1370's monolithic approach simplifies the design effort, allows operation at lower input voltages and reduces the board space required to implement a complete DC/DC converter.

For literature on our Boost Converters, call **1-800-4-LINEAR**. For applications help, call (408) 432-1900, Ext. 2593